

Indoor Type VCP-W Metal-Clad Switchgear Assembly (5/15 kV shown)



7.1	Introduction	
	Product Selection Guide	V3-T7-2
7.2	Metal-Clad Vacuum Switchgear	
	Product Overview	
	Product Description	V3-T7-4
	Application Description	V3-T7-4
	Features, Benefits and Functions	V3-T7-5
	Options and Accessories	V3-T7-6
	Technical Data and Specifications	V3-T7-6
	26-Inch Wide, 5 kV, 250 MVA, 1200A Switchgear	
	Product Description	V3-T7-7
	Application Description	V3-T7-7
	Features, Benefits and Functions	V3-T7-7
	Standards and Certifications	V3-T7-7
	38 kV Metal-Clad Switchgear	
	Product Description	V3-T7-8
	Application Description	V3-T7-8
	Features, Benefits and Functions	V3-T7-8
	Standards and Certifications	V3-T7-8
	Technical Data and Specifications	V3-T7-9
7.3	High Resistance Grounding System	
	Product Description	V3-T7-18
	Application Description	V3-T7-18
	Features, Benefits and Functions	V3-T7-21
	Standards and Certifications	V3-T7-21
	Catalog Number Selection	V3-T7-22
	Technical Data and Specifications	V3-T7-23
	Dimensions	V3-T7-26



Learn
Online

Indoor Type VCP-W Metal-Clad Switchgear Assembly (5/15 kV shown)



7

Contents

Description

Product Selection Guide

Product Selection Guide

Product Offering Chart—Metal-Enclosed ^①

Description	MVS	MEB	MSB	UPC	Mini-MVS
Voltage	5, 15, 27, 38 kV	5, 15 kV	5, 15 kV	5, 15 kV	5 kV only
Operation duty cycle	Low	High	High	Low	Low
Enclosure	Indoor, outdoor aisleless	Indoor, outdoor aisleless	Indoor, outdoor aisleless	Indoor only	Indoor, outdoor aisleless
Listed	UL [®] , CSA [®]	—	—	—	UL, CSA
Assembly standards	ANSI/IEEE [®] , C37.30.3, C37.20.4, C37.22, C37.57, C37.58, CSA 22.2 #31 ^②	ANSI/IEEE, C37.30.3, C37.20.4, C37.22, C37.57, C37.58, CSA 22.2 #31	ANSI/IEEE, C37.30.3, C37.20.4, C37.22, C37.57, C37.58, CSA 22.2 #31	—	ANSI/IEEE, C37.30.3, C37.20.4, C37.22, C37.57, C37.58, CSA 22.2 #31 ^②
Circuit breaker type	N/A	VCP-W	VCP-TR (5, 15 kV), VCP-W 27 kV	N/A	N/A
Circuit breaker mounted	N/A	Drawout	Fixed	N/A	N/A
Seismically rated Zone 4 to California Building Code Title 24	Yes	Yes	Yes	Yes	Yes
BIL ratings	60 kV (5 kV) 95 kV (15 kV) 125 kV (27 kV) 150 kV (38 kV)	60 kV (5 kV) 95 kV (15 kV)	60 kV (5 kV) 95 kV (15 kV) 125 kV (27 kV)	60 kV (5 kV) 95 kV (15 kV)	60 kV (5 kV)
Main bus ratings	800, 1200A (5/15/27/38 kV)	800, 1200A (5/15 kV)	800, 1200A (5/15/27 kV)	N/A	N/A, cable in, cable out application
Breaker ratings	N/A	1200A (5/15 kV)	600, 800, 1200A (5/15/27 kV)	N/A	N/A
Overcurrent protective device	Yes (fused)	Yes	Yes	Yes (fused)	Yes (fused)
Short-circuit interrupting capacity	Per fuse IC	29, 41, 63 kA (5 kV) 18, 28, 37, 63 kA (15 kV)	16, 20, 25, 40 kA (5/15 kV) 25 kA (27 kV)	Per fuse IC	Per fuse IC
Conduit entry	Top or bottom	Top or bottom	Top or bottom	Top or bottom	Top or bottom

Notes

^① Additional products not shown include medium voltage transfer, high resistance ground and low profile switchgear.

^② Listings are voltage dependant. See individual product sheets for detail.

Product Offering Chart—Metal-Clad ^①

Description	MVA Standard	Narrow Design	MVA Arc Resistant
Voltage	5, 15, 27, 38 kV	5 kV	5, 15, 27, 38 kV
Operation duty cycle	High	High	High
Enclosure	Indoor (5–38 kV)	Indoor only	Indoor only
	Outdoor aisleless (5–27 kV)	Outdoor aisle	
	Outdoor aisle (5–15 kV)		
	Outdoor common aisle (5–15 kV)		
Listed	UL, CSA	UL, CSA	CSA only
Assembly standards	ANSI/IEEE, C37.04, C37.06, C37.54, C37.20.2, C37.55, CSA 22.2 #31 ^②	ANSI/IEEE, C37.04, C37.06, C37.54, C37.20.2, C37.55, CSA 22.2 #31 ^②	ANSI/IEEE, C37.04, C37.06, C37.54, C37.20.2, C37.20.7, C37.55, CSA 22.2 #31 ^②
Circuit breaker type	VCP-W	VCP-W ND	VCP-W
Circuit breaker mounted	5 kV drawout, direct roll-in breaker option	Drawout 5 kV only	5 kV drawout, direct roll-in breaker option
	15 kV drawout, direct roll-in breaker option		15 kV drawout, direct roll-in breaker option
	27 kV drawout, direct roll-in breaker option		27 kV drawout, direct roll-in breaker option
	38 kV direct roll-in breakers		38 kV direct roll-in breakers
Seismically rated Zone 4 to California Building Code Title 24	Yes	Yes	Yes
BIL ratings	60 kV (5 kV)	60 kV (5 kV only)	60 kV (5 kV)
	95 kV (15 kV)		95 kV (15 kV)
	125 kV (27 kV)		125 kV (27 kV)
	170 kV (38 kV)		170 kV (38 kV)
Main bus ratings	1200, 2000, 3000, 4000A (5 kV)	1200A (5 kV only)	1200, 2000, 3000A (5 kV)
	1200, 2000, 3000, 4000A (15 kV)	2000A, 3000A	1200, 2000, 3000A (15 kV)
	1200, 2000A (27 kV)		1200, 2000A (27 kV)
	1200, 2000, 3000A depending on kA rating (38 kV)		1200, 2000, 3000A (38 kV)
Breaker ratings	1200, 2000, 3000A (5 kV)	1200A (5 kV only)	1200, 2000, 3000A (5 kV)
	1200, 2000, 3000A (15 kV)		1200, 2000, 3000A (15 kV)
	1200, 2000A (27 kV)		1200, 2000A (27 kV)
	1200, 1600, 2500A depending on kA rating (38 kV)		1200A (38 kV)
Overcurrent protective device	Yes	Yes	Yes
Short-circuit interrupting capacity	29, 41, 63 kA (5 kV)	29 kA (5 kV)	37 kA (5 kV) ^③
	33 kA (8.25 kV)		—
	18, 28, 37, 63 kA		37 kA (15 kV) ^③
	16, 22, 25, 40 kA		25 kA (27 kV) ^③
	16, 21, 25, 32, 40 kA (38 kV)		25 kA (38 kV) ^③
			40, 50, 63 kA (5 kV) ^③
		40, 50, 63 kA (15 kV) ^③	
		25, 40 kA (27 kV) ^③	
		25, 40 kA (38 kV) ^③	
Conduit Entry	Top or bottom	Top or bottom	Top or bottom

Notes

- ① Additional products not shown include medium voltage transfer, high resistance ground and low profile switchgear.
- ② Listings are voltage dependant. See individual product sheets for detail.
- ③ Ratings are arc ratings, not interrupting capacity.

VCP-W Breaker



7

Contents

Description

	<i>Page</i>
Product Overview	
Features, Benefits and Functions	V3-T7-5
Options and Accessories	V3-T7-6
Technical Data and Specifications	V3-T7-6
26-Inch Wide, 5 kV, 250 MVA, 1200A Switchgear .	V3-T7-7
38 kV Metal-Clad Switchgear	V3-T7-8



Product Overview

Product Description

Eaton has been manufacturing metal-clad switchgear for over 50 years, and vacuum circuit breakers for over 30 years. Tens of thousands of Eaton vacuum circuit breakers, used in a wide variety of applications, have been setting industry performance standards for years.

With reliability as a fundamental goal, Eaton's engineers have simplified the VCP-W switchgear design to minimize problems and gain trouble-free performance. Special attention was given to material quality and maximum possible use was made of components proven over the years in Eaton switchgear.

Maintenance requirements are minimized by the use of enclosed long-life vacuum interrupters. When maintenance or inspection is required, the component arrangements and drawers allow easy access. The VCP-W's light weight simplifies handling and relocation of the breakers.

The VCP-W meets or exceeds all applicable ANSI, NEMA® and IEEE design standards, and additionally offers many outstanding safety features. To ensure reliability and quality, the testing of VCP-W switchgears has been extensive. UL and CSA listed switchgear is available for 5 and 15 kV. CSA is available for 27 and 38 kV.

Application Description

Eaton's VCP-W metal-clad switchgear with type VCP-W vacuum breakers provides centralized control and protection of medium voltage power equipment and circuits in industrial, commercial and utility installations involving generators, motors, feeder circuits, and transmission and distribution lines.

VCP-W switchgear is available in maximum voltage ratings from 4.76 kV through 38 kV, and interrupting ratings as shown on **Page V3-T7-11**. VCP-W offers a total design concept of cell, breaker and auxiliary equipment, which can be assembled in various combinations to satisfy user application requirements. Two-high breaker arrangements are standard up to 15 kV. One-high arrangements can be furnished when required.

Features, Benefits and Functions

Endurance

High power laboratory tests prove VCP-W breakers are capable of 50 to 200 full fault current interruptions.

Space Savings

Up to 50% floor space reduction over previous designs.

Vacuum Interrupter, Current Transfer Conductor

Eaton's stiff-flexible design eliminates sliding/rolling contacts in the main conductor, which provides excellent electrical and thermal transfer, and long vacuum interrupter life.

Grounded Steel Safety Shutters

Prevents accidental contact with live primary voltage connections when breaker is withdrawn.

Breaker Rails

On 5–27 kV units, the breaker can be withdrawn on rails for inspection and maintenance without the need for a separate lifting device.

Direct Roll-In Breakers

5–27 kV switchgear is available with direct roll-in breakers. Direct roll-in breakers can be supplied in two-high configurations with fully interchangeable breakers. Rails or a special direct roll-in lift pan can be used if desired to withdraw upper breakers for inspection.

Reduced Breaker Weight

525 lbs (238 kg) maximum through 27 kV vs. 2450 lbs (1112 kg) in a comparable air-magnetic design for ease of handling.

Reduced Breaker Maintenance

Vacuum interrupter requires only periodic check for contact erosion. Integral wear indicator provided. No contact adjustments are required.

Front Accessible Mechanism

Front accessible mechanism is standard on all VCP-W breakers.

Front Accessible CTs (5–38 kV)

Up to 12 CTs per breaker can be mounted for easy access.

Drawout Auxiliary Compartments

Up to four drawers per vertical section can be equipped with CPTs or VTs up to 15 kV. Primary isolation shutters are standard.

Fluidized Bed Epoxy Bus Insulation

Excellent track resistant and flame retardant properties.

Standardized Functional Designs

Shortens order cycle time.

Protective Relays

A full scope of protective relays designed to meet all application requirements is available to provide the utmost in system and component protection. One such multipurpose relay system is Eaton's Digitrip™ FP-5000. FP-5000 enhanced capabilities include auto-throver schemes, voltage and current protection, and communication. This microprocessor-based circuit protective, control and monitoring relay system includes devices 50, 51, 50N, 51N, 50G, 51G and 86, plus cause and magnitude of trip, integral test and programming, ampere demand, high load alarm, non-volatile set points, self-testing and communications capabilities. The Digitrip is capable of being monitored and controlled through PowerNet™, DeviceNet™, Ethernet and Web PONIs. Refer to **Volume 3, Tab 9** for further information.

PowerNet—Integrated Monitoring Protection and Control Communications System

Medium voltage VCP-W switchgear is ideally suited for Eaton's unique PowerNet system.

PowerNet is the unique system that, for the first time, ties together multiple devices in electrical distribution systems in a wide variety of buildings and plants.

PowerNet uses the proven, INCOM™ chip for highly reliable, two-way communications (even in noisy industrial environments) between the master control unit and system devices via a twisted pair of conductors. Communications wires can be extended up to 10,000 feet (3.04m) from the master control unit without repeaters...and as many as 1000 compatible devices, installed in various assemblies, can be on the PowerNet system.

Easy Installation

Installation is uncomplicated and devices are connected, daisy chain style, via the twisted pair conductors. All assemblies and devices are standard Eaton equipment when PowerNet compatible devices are ordered as part of an assembly. The assemblies (with compatible devices built in) are prewired, pretested and delivered complete.

Flexibility

PowerNet is flexible in that it can include those assemblies, such as VCP-W switchgear, that are desired in a distribution system... but PowerNet can be easily upgraded as new assemblies are added. In essence, a customer determines the requirements for a building's electrical distribution system, and Eaton provides the PowerNet system to fit those specific requirements.

Environmentally-Friendly

Eaton's medium voltage switchgear uses vacuum switches combined with solid insulation material. This environmentally-friendly technology avoids the use of SF₆ as an insulation gas, and can offer a lower total cost of ownership over the complete life cycle of your medium voltage equipment.

Options and Accessories

Supplemental Devices

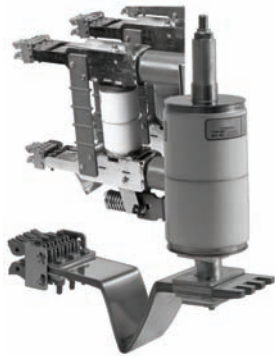

World-Class VCP-W Vacuum Circuit Breakers are Designed with a V-Flex Nonsliding Current Transfer System

Ground and Test Device

The ground and test device is a drawout element that may be inserted into a metal-clad switchgear housing in place of a circuit breaker to provide access to the primary circuits to permit the temporary connection of grounds or testing equipment to the high voltage circuits. High potential testing of cable or phase checking of circuits are typical tests that may be performed. The devices are insulated to suit the voltage rating of the switchgear and will carry required levels of short-circuit current.

Before using ground and test devices, it is recommended that each user develop detailed operating procedures consistent with safe operating practices. Only qualified personnel should be authorized to use ground and test devices.

Manual and electrical ground and test devices are available. These devices include six studs for connection to primary circuits. On the manual device, selection and grounding is accomplished by cable connection. On the electrical-type device, grounding is accomplished by an electrically operated grounding switch.

Standard Accessories

- One test jumper
- One levering crank
- One maintenance tool
- One lifting yoke (5–38 kV)
- Two sets of rails (5–27 kV)
- One turning handle (5th wheel, 38 kV)

Optional Accessories

- One transport dolly (5–27 kV)
- One portable lifter (5–27 kV)
- One test cabinet
- One electrical levering device (5–27 kV)
- One ramp for lower breaker (5–27 kV)
- One manual or electrical ground and test device. Electrical ground up to 15 kV only
- One hi-pot tester
- One offset manual racking device

Technical Data and Specifications

- Maximum voltages:
 - 4.76 kV, 8.25 kV, 15 kV, 27 kV, 38 kV
- Interrupting ratings:
 - 4.76 kV:
 - 250 MVA (29 kA)
 - 350 MVA (41 kA)
 - 500 MVA (63 kA)
 - 8.25 kV:
 - 500 MVA (33 kA)
 - 15 kV:
 - 500 MVA (18 kA)
 - 750 MVA (28 kA)
 - 1000 MVA (37 kA)
 - 1500 MVA (63 kA)
 - 27 kV:
 - 16 kA, 22 kA, 25 kA, 40 kA
 - 38 kV:
 - 16 kA, 25 kA, 31.5 kA, 40 kA
 - 2300 MVA (35 kA)
- Continuous current: circuit breakers
 - 1200A, 2000A, 3000A (5 and 15 kV)
 - 4000A forced cooled (5 and 15 kV)
 - 1200A, 2000A, (27 kV)
 - 600A, 1200A, 1600A, 200A, 2500A (38 kV)
 - 3000A forced cooled (38 kV)
- Continuous current: main bus
 - 1200A, 2000A, 3000A, 4000A (5 and 15 kV)
 - 1200A, 2000A, (27 kV)
 - 1200A, 2000A, 2500A, 3000A (38 kV)

Typical Indoor Assembly with a Breaker Withdrawn on Rails



Contents

Description	Page
Product Overview	V3-T7-4
26-Inch Wide, 5 kV, 250 MVA, 1200A Switchgear	
38 kV Metal-Clad Switchgear	V3-T7-8

26-Inch Wide, 5 kV, 250 MVA, 1200A Switchgear

Product Description

26-inch wide VCP-W switchgear was designed for use in instances where floor space requirements would not allow the industry standard 36-inch (914.4 mm) wide switchgear.

Application Description

Typical applications include not only new construction, but also replacement switchgear for installations previously equipped with 26-inch (660.4 mm) wide airbreak devices. This new line of switchgear has also proven very popular among Generator Control manufacturers where 5 kV, 250 MVA, 1200A applications are commonplace.

Features, Benefits and Functions

Functionality is the name of the game. Available configurations include breaker over breaker, one or two auxiliaries over breaker, breaker over one or two auxiliaries, or up to four auxiliaries in one vertical section.

In addition to the tremendous floor space saving offered by the 26-inch (660.4 mm) wide design, a savings in the height of the switchgear is also available. Where height is an issue, such as an outdoor powerhouse or in a mobile power container, the standard 95-inch (2413 mm) height can be reduced to an 80-inch (2032 mm) tall model with a single-high breaker with one auxiliary and/or control cubical. In addition, the low-profile structure is designed to accommodate Voltage Transformers that are front mounted. Shallow-depth versions are also available for applications where depth is an issue. Contact your local Eaton representative for more information on special dimensional requirements.

For installations requiring 2000A main breakers with 1200A feeders, lineups can be built with standard 36-inch (914.4 mm) wide main breaker cubicles and 26-inch (660.4 mm) wide feeders. The main bus connections are 100% compatible with standard 36-inch (914.4 mm) wide vertical sections. As a result, add-ons to existing installations can be simply and rapidly performed without costly system modifications and transition sections.

Standards and Certifications

At the heart of the new switchgear line is Eaton's world-class VCPW-ND "Narrow Design" vacuum circuit breaker. The 26-inch (660.4 mm) wide offering includes breakers and gear that are rated for use on 5 kV, 250 MVA, 1200A, 60 kV BIL maximum systems. Main bus ratings of up to 2000A are available.

The 26-inch (660.4 mm) wide VCP-W switchgear meets or exceeds ANSI, NEMA and IEEE design standards. UL and CSA listed switchgear is also available.



Typical Indoor Switchgear Unit



7

Contents

<i>Description</i>	<i>Page</i>
Product Overview	V3-T7-4
26-Inch Wide, 5 kV, 250 MVA, 1200A Switchgear	V3-T7-7
38 kV Metal-Clad Switchgear	
Technical Data and Specifications	V3-T7-9

38 kV Metal-Clad Switchgear

Product Description

This member of the Eaton's VCP-W switchgear family was designed for use in applications with distribution voltages at 38 kV maximum.

Application Description

Typical applications include not only new construction, but also replacement for older airbreak, minimum oil or SF₆ switchgear. This line is available in two basic versions: one designed specifically for domestic and export ANSI applications (VCP-W), with a continuous current range of 600–2500A; and one built for export only IEC applications (W-VAC) for continuous current ranges of 630–2500A.

Features, Benefits and Functions

Both ANSI and IEC versions offer 40 kA rms symmetrical momentary short-circuit, 80 kV 1 minute withstand, 170 kV BIL ratings as standard, and both feature a revolutionary interface design that permits crossover and transition bus connections to adjacent sections without the need for a transition section. Standard dimensions of this 170 kV BIL gear is 42 inches wide x 100 inches tall x 128.8 inches deep (1066.8 mm wide x 2540 mm tall x 3270.3 mm deep), making the VCP-W offering the smallest in its class.

Safety has been thoroughly addressed in the design of the 38 kV VCP-W. On all standard units, shutters can be independently padlocked to prevent inadvertent energizing during maintenance. Where needed, fully rated feeder earthing switches are also available.

Ease of service is another benefit. All 38 kV switchgear units are equipped with roll-on-the-floor vacuum circuit breakers that provide both unprecedented mobility and ready accessibility to the breaker cell. Levering-in mechanisms for breaker installation employ an innovative ball-screw bearing drive that can be operated by a single technician.

The 38 kV line can be equipped with a variety of optional features to enhance system protection and monitoring. Eaton's Digitrip FP-5000 microprocessor-based trip system, IQ Analyzer and the PowerNet communications system are all available with the 38 kV metal-clad switchgear.

Standards and Certifications

Both ANSI and IEC designs are designed and tested at the factory to be corona-free. In addition, optional arc-resistant designs can be specified to comply with EEMAC G-14-1 for Accessibility Types A and B.

CSA listed switchgear is also available.



Technical Data and Specifications

Available Type VCP-W Vacuum Circuit Breakers Rated on Symmetrical Current Basis, Per ANSI Standards (Rated K=1)

Rated Values	Drawout Circuit Breaker Type				
	50 VCP-W 25	50 VCP-W 40	50 VCP-W 50	50 VCP-W 63	75 VCP-W 40
Maximum voltage (V) (kV rms)	4.76	4.76	4.76	4.76	8.25
Power frequency (Hz) ①	60	60	60	60	60
Insulation level					
Power frequency withstand voltage (1 min.) (kV rms)	19	19	19	19	36
Lightning impulse withstand voltage (1.2 x 50 ms) (kV peak)	60	60	60	60	95
Continuous current (A rms) ②	1200 2000 3000	1200 2000 3000	1200 2000 3000	1200 2000 3000	1200 2000 3000
Short-circuit ratings (reference C37.04-1999 and C37.06-2009 except as noted ③)					
Symmetrical interrupting circuit (I) (kA rms sym) ④	25	40	50	63	40
DC component (%DC) (%) ⑤	50	50	44	55	50
Asymmetrical interrupting current (I _a) (kA rms asym total) ⑥	31	49	59	80	49
Closing and latching current (2.6 x I) (kA peak)	65	104	130	164	104
Short-time withstand current (rms) ⑦	25	40	50	63	40
Transient recovery voltage parameters are based on TD-4					
Peak voltage (E ₂) = (u _c) (kV peak)	8.2	8.2	8.2	8.2	14
Time to peak (T ₂ = t ₃ x 1.137) (msec)	50	50	50	50	59
TRV rise time (t ₃) (msec)	44	44	44	44	52
RRRV = u _c /t ₃ (kV/msec) ⑧	0.19	0.19	0.19	0.19	0.27
Interrupting time (ms, cycles (60 Hz))	50, 3	50, 3	50, 3	50, 3	50, 3
Operating duty (duty cycle)	0-0.3s-CO-3m-CO	0-0.3s-CO-3m-CO	0-0.3s-CO-3m-CO	0-0.3s-CO-3m-CO	0-0.3s-CO-3m-CO
Mechanical endurance (no-load operations) ⑨⑩	10,000	10,000	10,000	10,000	10,000
Capacitance current switching capability (reference C47.04a-2003, C37.06-2009 and C37.09a-2005)					
Cable-charging current (class, A rms)	C2, 3-10	C2, 3-10	C2, 3-10	C2, 7.5-25	C2, 7.5-25
Isolated shunt capacitor bank current (class, A rms)	C2, 75-630 75-1000 75-1600	C2, 75-630 75-1000 75-1600	C2, 75-630 75-1000 75-1600	C2, 75-630 75-1000 75-1600	C2, 75-630 75-1000 75-1600
Back-to-back capacitor switching					
Capacitor bank current (class, A rms)	C2, 75-630 75-1000 75-1600	C2, 75-630 75-1000 75-1600	C2, 75-630 75-1000 75-1600	C2, 75-630 75-1000 75-1600	C2, 75-630 75-1000 75-1600
Inrush current (kA peak)	6	6	6	6	6
Inrush frequency (kHz)	0.8 0.5 0.3	0.8 0.5 0.3	0.8 0.5 0.3	0.8 0.5 0.3	0.8 0.5 0.3
Out-of-phase switching					
Voltage = 1.44 x V (kV rms)	7	7	7	7	12
Current = 0.25 x I (kA rms)	6.3	10	12.5	15.8	10

Notes

- ① All circuit breakers are tested at 60 Hz, however, they can also be applied at 50 Hz with no de-rating.
- ② 4000A fan cooled rating is available for 3000A circuit breakers.
- ③ These circuit breakers were tested to the preferred TRV ratings specified in C37.06-2000.
- ④ Because the voltage range factor K=1, the short-time withstand current and the maximum symmetrical interrupting current are equal to the rated symmetrical interrupting current.
- ⑤ Based on the standard DC TIME constant of 45 ms (corresponding to X/R of 17 for 60 Hz) and the minimum contact parting time as determined from the minimum opening time plus the assumed minimum relay time of 1/2 cycle (8.33 ms for 60 Hz).
- ⑥ The asymmetrical interrupting current, I total, is given by $I_t = I \times \text{Sqrt}(1 + 2 \times \%DC \times \%DC)$ kA rms asym total.
- ⑦ Duration of short-time current and maximum permissible tripping delay are both two seconds for all circuit breakers listed in this table, as required in C37.04-1999, C37.06-2000 and C37.06-2009.
- ⑧ RRRV can also be calculated as $= 1.137 \times E_2/T_2$.
- ⑨ Each operation consists of one closing plus one opening.
- ⑩ All 40 and 50 kA circuit breakers exceed required 5000 no-load operations; all 63 kA circuit breakers exceed the required 2000 no-load ANSI operations.

Available Type VCP-W Vacuum Circuit Breakers Rated on Symmetrical Current Basis, Per ANSI Standards (Rated K=1), continued

Rated Values	Drawout Circuit Breaker Type				
	75 VCP-W 50	150 VCP-W 25	150 VCP-W 40	150 VCP-W 50	150 VCP-W 63
Maximum voltage (V) (kV rms)	8.25	15	15	15	15
Power frequency (Hz) ①	60	60	60	60	60
Insulation level					
Power frequency withstand voltage (1 min.) (kV rms)	36	36	36	36	36
Lightning impulse withstand voltage (1.2 x 50 ms) (kV peak)	95	95	95	95	95
Continuous current (A rms) ②	1200 2000 3000	1200 ③ 2000 3000	1200 2000 3000	1200 2000 3000	1200 ③ 2000 ③ 3000 ③
Short-circuit ratings (reference C37.04-1999 and C37.06-2009 except as noted ③)					
Symmetrical interrupting current (I) (kA rms sym) ④	50	25	40	50	63
DC component (%DC) (%) ⑤	44	50	50	44	55
Asymmetrical interrupting current (I _a) (kA rms asym total) ⑥	59	31	49	59	80
Closing and latching current (2.6 x I) (kA peak)	130	65	104	130	164
Short-time withstand current (rms) ⑦	50	25	40	50	63
Transient recovery voltage parameters are based on TD-4					
Peak voltage (E ₂) = (u _c) (kV peak)	14	28 ⑧ 25.7	25.7	25.7	28 ⑧
Time to peak (T ₂ = t ₃ x 1.137) (msec)	59	75	75	75	75
TRV rise time (t ₃) (msec)	52	66	66	66	66
RRRV = u _c /t ₃ (kV/msec) ⑨	0.27	0.42 0.39	0.39	0.39	0.42
Interrupting time (ms, cycles (60 Hz))	50, 3	50, 3	50, 3	50, 3	50, 3
Operating duty (duty cycle)	0-0.3s-CO-3m-CO	0-0.3s-CO-3m-CO	0-0.3s-CO-3m-CO	0-0.3s-CO-3m-CO	0-0.3s-CO-3m-CO
Mechanical endurance (no-load operations) ⑩⑪	10,000	10,000	10,000	10,000	10,000
Capacitance current switching capability (reference C47.04a-2003, C37.06-2009 and C37.09a-2005)					
Cable-charging current (class, A rms)	C2, 7.5–25	C2, 7.5–25	C2, 7.5–25	C2, 7.5–25	C2, 7.5–25
Isolated shunt capacitor bank current (class, A rms)	C2, 75–630 75–1000 75–1600	C2, 75–630 C2, 75–1000 C1, 75–1000	C2, 75–630 C2, 75–1000 C1, 75–1600	C2, 75–630 C2, 75–1000 C1, 75–1600	C2, 75–630 75–1000 75–1600
Back-to-back capacitor switching					
Capacitor bank current (class, A rms)	C2, 75–630 75–1000 75–1600	C2, 75–630 C2, 75–1000 C1, 75–1000	C2, 75–630 C2, 75–1000 C1, 75–1600	C2, 75–630 C2, 75–1000 C1, 75–1600	C2, 75–630 75–1000 75–1600
Inrush current (kA peak)	6	6	6	6	6
Inrush frequency (kHz)	0.8 0.5 0.3	0.8 0.5 0.3	0.8 0.5 0.3	0.8 0.5 0.3	0.8 0.5 0.3
Out-of-phase switching					
Voltage = 1.44 x V (kV rms)	12	22	22	22	22
Current = 0.25 x I (kA rms)	12.5	6.3	10	12.5	15.8

Notes

- ① All circuit breakers are tested at 60 Hz, however, they can also be applied at 50 Hz with no de-rating.
- ② 4000A fan cooled rating is available for 3000A circuit breakers.
- ③ These circuit breakers were tested to the preferred TRV ratings specified in C37.06-2000.
- ④ Because the voltage range factor K=1, the short-time withstand current and the maximum symmetrical interrupting current are equal to the rated symmetrical interrupting current.
- ⑤ Based on the standard DC time constant of 45 ms (corresponding to X/R of 17 for 60 Hz) and the minimum contact parting time as determined from the minimum opening time plus the assumed minimum relay time of 1/2 cycle (8.33 ms for 60 Hz).

- ⑥ The asymmetrical interrupting current, I total, is given by $I_a = I \times \text{Sqrt}(1 + 2 \times \%DC \times \%DC)$ kA rms asym total.
- ⑦ Duration of short-time current and maximum permissible tripping delay are both two seconds for all circuit breakers listed in this table, as required in C37.04-1999, C37.06-2000 and C37.06-2009.
- ⑧ RRRV can also be calculated as $= 1.137 \times E_2/T_2$.
- ⑨ Each operation consists of one closing plus one opening.
- ⑩ All 40 and 50 kA circuit breakers exceed required 5000 no-load operations; all 63 kA circuit breakers exceed the required 2000 no-load ANSI operations.

Available VCP-W Vacuum Circuit Breaker Types Rated on Symmetrical Current Rating Basis, Per ANSI Standards ①②

	Circuit Breaker Type							
	50 VCP-WND 250	50 VCP-W 250	50 VCP-W 350	50 VCP-W 63	75 VCP-W 500	150 VCP-W 500	150 VCP-W 750	150 VCP-W 1000
Identification								
Nominal voltage class kV	4.16	4.16	4.16	4.16	7.2	13.8	13.8	13.8
Nominal three-phase MVA class	250	250	350	—	500	500	750	1000
Rated Values								
Voltage								
Rated maximum voltage V kV rms	4.76	4.76	4.76	4.76	8.25	15	15	15
Rated voltage range factor K ③	1.24	1.24	1.19	1.0	1.25	1.30	1.30	1.30
Insulation level—rated withstand test voltage								
Normal frequency kV rms	19	19	19	19	36	36	36	36
1.2 x 50 μsec. impulse kV crest	60	60	60	60	95	95	95	95
Current								
Rated continuous current at 60 Hz amp ④	1200	1200	1200	1200	1200	1200	1200	1200
	—	2000	2000	2000	2000	2000	2000	2000
	—	3000	3000	3000	3000	3000	3000	3000
Rated short-circuit current (at rated maximum kV)—I kA rms ⑤	29	29	41	63	33	18	28	37
Rated transient recovery voltage								
Rated crest voltage —E ₂ kV crest	8.9	8.9	8.9	8.9	15.5	28	28	28
Rated time to crest—T ₂ μs	50	50	50	50	60	75	75	75
Rate of rise of recovery voltage kV/μs ⑥	0.2	0.2	0.2	0.2	0.29	0.42	0.42	0.42
Rated interrupting time cycles ⑥	5	5	5	5	5	5	5	5
Rated permissible tripping delay—Y sec. ⑦	2	2	2	2	2	2	2	2
Rated reclosing time ms ⑧	300	300	300	300	300	300	300	300
Related Required Capabilities								
Rated maximum voltage divided by K—V/K kV rms	3.85	3.85	4.0	4.76	6.6	11.5	11.5	11.5
Current values								
K times rated short-circuit current ③								
Maximum sym. interrupting capability—KI kA rms	36	36	49	63	41	23	36	48
Three-second short-time current carrying capability—KI kA rms	36	36	49	63	41	23	36	48
Closing and latching capability (momentary) ⑨								
2.7K times rated short-circuit current—2.7 KI kA crest	97	97	132	170	111	62	97	130
1.6K times rated short-circuit current—1.6 KI kA rms asym. ⑩	58	58	78	101	66	37	58	77
Asymmetry Factor for VCP-W Breakers (S) ⑪	1.2	1.2	1.2	1.27	1.2	1.2	1.2	1.2

Notes

- ① For capacitor switching, refer to **Page V3-T7-14**.
- ② 5 and 15 kV circuit breakers are UL listed. 27 and 38 kV breakers are not UL listed.
- ③ For three-phase and line-to-line faults, the symmetrical interrupting capability at an operating voltage

$$I_{sc} = \frac{V}{V_0} \text{ (Rated Short-Circuit Current)}$$

But not to exceed KI.

Single line-to-ground fault capability at an operating voltage

$$I_{sc} = 1.15 \frac{V}{V_0} \text{ (Rated Short-Circuit Current)}$$

But not to exceed KI.

The above apply on predominately inductive or resistive three-phase circuits with normal-frequency line-to-line recovery voltage equal to the operating voltage.

- ④ 4000A continuous rating is available for 5/15 kV. 3000A continuous rating is available for 38 kV. Contact Eaton for details.

$$\text{⑤ } RRRV = 1.137 \frac{E_2}{T_2}$$

- ⑥ Three-cycle rating available, refer to **Page V3-T7-14**.

- ⑦ Tripping may be delayed beyond the rated permissible tripping delay at lower values of current in accordance with the following formula:

$$T \text{ (seconds)} = Y \left(\frac{\text{(K Times Rated Short-Circuit Current)}}{\text{Short-Circuit Current Through Breaker}} \right)^2$$

The aggregate tripping delay on all operations within any 30-minute period must not exceed the time obtained from the above formula.

- ⑧ For reclosing service, there is **No De-Rating** necessary Eaton's VCP-W family of circuit breakers. **R = 100%**. Type VCP-W breaker can perform the O-C-O per ANSI C37.09; O-0.3s-CO-15s-CO per IEC 56; and some VCP-Ws have performed O-0.3s-CO-15s-CO-15s-CO-15s-CO; **all with no derating**. Contact Eaton for special reclosing requirements.
- ⑨ For higher close and latch ratings, refer to **Page V3-T7-14**.
- ⑩ Included for reference only.
- ⑪ Asymmetrical interrupting capability = "S" times symmetrical interrupting capability, both at specified operating voltage.

Available VCP-W Vacuum Circuit Breaker Types Rated on Symmetrical Current Rating Basis, Per ANSI Standards, continued ①②

	Circuit Breaker Type				
	150 VCP-W 63	270 VCP-W 750	270 VCP-W 1000	270 VCP-W 1250	270 VCP-W 40
Identification					
Nominal voltage class kV	13.8	27	27	27	27
Nominal three-phase MVA class	—	—	—	—	—
Rated Values					
Voltage					
Rated maximum voltage kV rms	15	27	27	27	27
Rated voltage range factor K ③	1.0	1.0	1.0	1.0	1.0
Insulation level—rated withstand test voltage					
Normal frequency kV rms	36	60	60	60	60
1.2 x 50 μsec. impulse kV crest	95	125	125	125	125
Current					
Rated continuous current at 60 Hz amp ④	1200	600	600	600	1200
	2000	1200	1200	1200	2000
	3000	2000	2000	2000	—
Rated short-circuit current (at rated maximum kV)—I kA rms ⑤	63	16	22	25	40
Rated transient recovery voltage					
Rated crest voltage—E ₂ kV crest	28	51	51	51	51
Rated time to crest—T ₂ μs	75	105	105	105	105
Rate of rise of recovery voltage kV/μs ⑥	0.42	0.55	0.55	0.55	0.55
Rated interrupting time cycles ⑦	5	5	5	5	5
Rated permissible tripping delay—Y sec. ⑦	2	2	2	2	2
Rated reclosing time ms ⑧	300	300	300	300	300
Related Required Capabilities					
Rated maximum voltage divided by K—V/K kV rms	15	27	27	27	27
Current values					
K times rated short-circuit current ③					
Maximum sym. interrupting capability—KI kA rms	63	16	22	25	40
Three-second short-time current carrying capability—KI kA rms	63	16	22	25	40
Closing and latching capability (momentary) ⑨					
2.7K times rated short-circuit current—2.7 KI kA crest	170	43	60	68	108
1.6K times rated short-circuit current—1.6 KI kA rms asym. ⑩	100	26	35	40	64
Asymmetry Factor for VCP-W Breakers (S) ⑪	1.27	1.2	1.2	1.2	1.2

Notes

- ① For capacitor switching, refer to **Page V3-T7-14**.
 ② 5 and 15 kV circuit breakers are UL listed. 27 and 38 kV breakers are not UL listed.
 ③ For three-phase and line-to-line faults, the symmetrical interrupting capability at an operating voltage

$$I_{sc} = \frac{V}{V_0} \text{ (Rated Short-Circuit Current)}$$

But not to exceed KI.

Single line-to-ground fault capability at an operating voltage

$$I_{sc} = 1.15 \frac{V}{V_0} \text{ (Rated Short-Circuit Current)}$$

But not to exceed KI.

The above apply on predominately inductive or resistive three-phase circuits with normal-frequency line-to-line recovery voltage equal to the operating voltage.

- ④ 4000A continuous rating is available for 5/15 kV. 3000A continuous rating is available for 38 kV. Contact Eaton for details.

$$\text{⑥ } RRRV = 1.137 \frac{E_2}{T_2}$$

- ⑤ Three-cycle rating available, refer to **Page V3-T7-14**.
 ⑦ Tripping may be delayed beyond the rated permissible tripping delay at lower values of current in accordance with the following formula:

$$T \text{ (seconds)} = Y \left(\frac{K \text{ Times Rated Short-Circuit Current}}{\text{Short-Circuit Current Through Breaker}} \right)^2$$

The aggregate tripping delay on all operations within any 30-minute period must not exceed the time obtained from the above formula.

- ⑧ For reclosing service, there is **No De-Rating** necessary for Eaton's VCP-W family of circuit breakers. **R = 100%**. Type VCP-W breaker can perform the O-C-O per ANSI C37.09; O-0.3s-CO-15s-CO per IEC 56; and some VCP-Ws have performed O-0.3s-CO-15s-CO-15s-CO-15s-CO; **all with no derating**. Contact Eaton for special reclosing requirements.
 ⑨ For higher close and latch ratings, refer to **Page V3-T7-14**.
 ⑩ Included for reference only.
 ⑪ Asymmetrical interrupting capability = "S" times symmetrical interrupting capability, both at specified operating voltage.

Available VCP-W Vacuum Circuit Breaker Types Rated on Symmetrical Current Rating Basis, Per ANSI Standards, continued ^{①②}

	Circuit Breaker Type				
	380 VCP-W 16	380 VCP-W 21	380 VCP-W 25	380 VCP-W 32	380 VCP-W 40
Identification					
Nominal voltage class kV	34.5	34.5	34.5	34.5	34.5
Nominal three-phase MVA class	—	—	—	—	—
Rated Values					
Voltage					
Rated maximum voltage kV rms	38	38	38	38	38
Rated voltage range factor K ^③	1.0	1.65	1.0	1.0	1.0
Insulation level—rated withstand test voltage Normal frequency kV rms					
	80	80	80	80	80
1.2 x 50 μsec. impulse kV crest ^④	170 ^⑤	170 ^⑤	170 ^⑤	170 ^⑤	170 ^⑤
Current					
Rated continuous current at 60 Hz amp ^④	600	1200	600	600	600
	1200	2000	1200	1200	1200
	1600	—	1600	1600	1600
	2000	—	2000	2000	2000
	—	—	—	2500	2500
Rated short-circuit current (at rated maximum kV)—I kA rms ^③	16	21	25	31.5	40
Rated transient recovery voltage					
Rated crest voltage —E ₂ kV crest	71	71	71	71	71
Rated time to crest—T ₂ μs	125	125	125	125	125
Rate of rise of recovery voltage kV/μs ^⑤	0.64	0.64	0.64	0.64	0.64
Rated interrupting time cycles ^⑥	5	5	5	5	5
Rated permissible tripping delay—Y sec. ^⑦	2	2	2	2	2
Rated reclosing time ms ^⑧	300	300	300	300	⑨
Related Required Capabilities					
Rated maximum voltage divided by K—V/K kV rms	38	23	38	38	38
Current values					
K times rated short-circuit current ^③					
Maximum sym. interrupting capability—KI kA rms	16	35	25	31.5	40
Three-second short-time current carrying capability—KI kA rms	16	35	25	31.5	40
Closing and latching capability (momentary) ^⑩					
2.7K times rated short-circuit current—2.7 KI kA crest	43	95	68	85	108
1.6K times rated short-circuit current—1.6 KI kA rms asym. ^⑪	26	56	40	51	64
Asymmetry Factor for VCP-W Breakers (S) ^⑫	1.2	1.2	1.2	1.2	1.2

Notes

- ① For capacitor switching, refer to **Page V3-T7-14**.
- ② 5 and 15 kV circuit breakers are UL listed. 27 and 38 kV breakers are not UL listed.
- ③ For three-phase and line-to-line faults, the symmetrical interrupting capability at an operating voltage

$$I_{sc} = \frac{V}{V_0} \text{ (Rated Short-Circuit Current)}$$

But not to exceed KI.
Single line-to-ground fault capability at an operating voltage

$$I_{sc} = 1.15 \frac{V}{V_0} \text{ (Rated Short-Circuit Current)}$$

But not to exceed KI.
The above apply on predominately inductive or resistive three-phase circuits with normal-frequency line-to-line recovery voltage equal to the operating voltage.
- ④ 4000A continuous rating is available for 5/15 kV. 3000A continuous rating is available for 38 kV. Contact Eaton for details.

$$\textcircled{5} \text{ RRRV} = 1.137 \frac{E_2}{T_2}$$

- ⑥ Three-cycle rating available, refer to **Page V3-T7-14**.
- ⑦ Tripping may be delayed beyond the rated permissible tripping delay at lower values of current in accordance with the following formula:

$$T \text{ (seconds)} = Y \left(\frac{K \text{ Times Rated Short-Circuit Current}}{\text{Short-Circuit Current Through Breaker}} \right)^2$$

The aggregate tripping delay on all operations within any 30-minute period must not exceed the time obtained from the above formula.
- ⑧ For reclosing service, there is **No De-Rating** necessary for Eaton's VCP-W family of circuit breakers. **R = 100%**. Type VCP-W breaker can perform the O-C-O per ANSI C37.09; O-0.3s-CO-15s-CO per IEC 56; and some VCP-Ws have performed O-0.3s-CO-15s-CO-15s-CO-15s-CO; **all with no derating**. Contact Eaton for special reclosing requirements.
- ⑨ For higher close and latch ratings, refer to **Page V3-T7-14**.
- ⑩ Included for reference only.
- ⑪ Asymmetrical interrupting capability = "S" times symmetrical interrupting capability, both at specified operating voltage.
- ⑫ ANSI standard requires 150 kV BIL. All 38 kV ratings are tested to 170 kV BIL.
- ⑬ Type 380 VCP-2 40 circuit breaker is not rated for rapid reclosing.

Extra Capability Type VCP-WC Ratings (Symmetrical Current Basis)

	Circuit Breaker Type				
	50 VCP-W 25C	50 VCP-W 40C	50 VCP-W 50C	50 VCP-W 63C	75 VCP-W 50C
Rated Values					
Voltage					
Maximum voltage V kV rms	5.95	5.95	5.95	5.95	10.3
Voltage range factor K	1	1	1	1	1
Insulation level—withstanding					
Power frequency (1 min.) kA rms total	24	24	24	24	42
Lighting impulse 1.2 x 50 μ s kV peak	75	75	75	75	95
Continuous current at 60 Hz A rms	1200	1200	1200	1200	1200
	2000	2000	2000	2000	2000
	3000 ^④	3000 ^④	3000 ^④	3000 ^④	3000 ^④
Short-circuit current					
Sym. interrupting at voltage (I _{sc}) kA rms total	25	40	50	63	50
% DC component (I _{dc})	50	75	57	62	57
	75	—	57	—	57
	75	—	52	—	52
Asym. interrupting (I _l) kA rms	31	58	64	83	64
	36	—	64	—	64
	36	—	62	—	62
Closing and latching capability kA peak	97	139	139	175	139
Short-time current for 3 seconds kA rms ^①	25	40	50	63	50
Interrupting time ms ^②	50	50	50	50	50
Maximum permissible tripping delay sec.	2.0	2.0	2.0	2.0	2.0
Rate of rise of recovery voltage (RRRV) kV/ μ s ^③	0.9	0.9	0.9	1.1	0.9
	0.9	0.9	0.9	—	0.9
	0.8	0.8	0.8	—	0.8
Capacitor switching ratings					
General purpose—isolated shunt capacitor bank current A rms	400 and 630	630 ^⑤	630 ^⑤	250	630 ^⑤
	1000 ^⑤	1000 ^⑤	1000 ^⑤	—	1000 ^⑤
	250	250	250	—	250
Definite purpose—back-to-back capacitor switching					
Capacitor bank current A rms	400 and 630	630 ^⑥	630 ^⑥	200, 1600 ^⑦	630 ^⑥
	1000 ^⑥	1000 ^⑥	1000 ^⑥	200, 1600 ^⑦	1000 ^⑥
	—	—	—	200, 1600 ^⑦	—
Inrush current kA peak	20 and 20	15	15	7.7	15
	18	18	18	7.7	18
	—	—	—	7.7	—
Inrush frequency kHz	6.5 and 5.5	3.5	3.5	465	3.5
	2.7	2.7	2.7	465	2.7
	—	—	—	465	—
Mechanical Endurance—No-Load Operations	10,000	10,000	10,000	10,000	10,000
	10,000	10,000	10,000	10,000	10,000
	5000	5000	5000	5000	5000

Notes

- ① Except as noted.
- ② Three cycles.
- ③ Contact Eaton for higher RRRV or for more information.
- ④ 4000A FC rating available.
- ⑤ Breaker tested to 2700A single bank switching for momentary load (thermal de-rating must consider harmonic content of current waveform).
- ⑥ Breaker tested to 1270A back-to-back switching for momentary load (thermal de-rating must consider harmonic content of current waveform).
- ⑦ C37.04.a-2003 Class C2 at 15 kV.
38 kV, 2500A and 3000A WC breakers are not rated for rapid reclosing.

Extra Capability Type VCP-WC Ratings (Symmetrical Current Basis), continued

Rated Values	Circuit Breaker Type				
	150 VCP-W 25C	150 VCP-W 40C	150 VCP-W 50C	150 VCP-W 63C	270 VCP-W 25C
Voltage					
Maximum voltage V kV rms	17.5	17.5	17.5	15	27
Voltage range factor K	1	1	1	1	1
Insulation level—withstanding test					
Power frequency (1 min.) kA rms total	42	42	42	42	60
Lighting impulse 1.2 x 50 μ s kV peak	95	96	95	95	125
Continuous current at 60 Hz A rms					
	1200	1200	1200	1200	1200
	2000	2000	2000	2000	1600
	3000 ^④	3000 ^④	3000 ^④	3000 ^④	—
Short-circuit current					
Sym. interrupting at voltage (Isc) kA rms total	25	40	50	63	25
% DC component (Idc)					
	50	75	57	62	75
	75	—	57	—	—
	75	—	52	—	—
Asym. interrupting (I_l) kA rms					
	31	58	64	83	36
	36	—	64	—	—
	36	—	62	—	—
Closing and latching capability kA peak	97 ^⑤	139	139	175	85
Short-time current for 3 seconds kA rms ^①	25	40	50	63	25 ^⑥
Interrupting time ms ^②	50	50	50	50	50
Maximum permissible tripping delay sec.	2.0	2.0	2.0	2.0	2.0
Rate of rise of recovery voltage (RRRV) kV/μs^③					
	0.9	0.9	0.9	1.1	1.1
	0.9	0.9	0.9	—	—
	0.8	0.8	0.8	—	—
Capacitor switching ratings					
General purpose—isolated shunt capacitor bank current A rms					
	400A and 630 ^⑦	630 ^{⑦⑧}	630 ^{⑦⑧}	250	400
	1000 ^{⑦⑧}	1000 ^{⑦⑧}	1000 ^{⑦⑧}	—	—
	250 ^⑦	250 ^⑦	250 ^⑦	—	—
Definite purpose—back-to-back capacitor switching					
Capacitor bank current A rms					
	400 and 600 ^⑦	630 ^{⑦⑧}	630 ^{⑦⑧}	200, 1600 ^⑨	400
	1000 ^{⑦⑧}	1000 ^{⑦⑧}	1000 ^{⑦⑧}	200, 1600 ^⑨	—
	—	—	—	200, 1600 ^⑨	—
Inrush current kA peak					
	20 and 20	15	15	7.7	20
	18	18	18	7.7	—
	—	—	—	7.7	—
Inrush frequency kHz					
	6.5 and 5.5	3.5	3.5	465	4.2
	2.7	2.7	2.7	465	—
	—	—	—	465	—
Mechanical Endurance—No-Load Operations					
	10,000	10,000	10,000	10,000	5000
	10,000	10,000	10,000	10,000	—
	5000	5000	5000	5000	—

Notes

- ① Except as noted.
 - ② Three cycles.
 - ③ Contact Eaton for higher RRRV or for more information.
 - ④ 4000A FC rating available.
 - ⑤ Close and latch current for 1200A Type 150 VCP-W 25C is proven at 15 kV. For sealed interrupters at high altitudes, switching voltage is not de-rated.
 - ⑥ 2.5 seconds.
 - ⑦ Capacitor switching ratings are proven at 15 kV. For sealed interrupters at high altitudes, switching voltage is not de-rated.
 - ⑧ Breaker tested to 2700A single bank switching for momentary load (thermal de-rating must consider harmonic content of current waveform).
 - ⑨ Breaker tested to 1270A back-to-back switching for momentary load (thermal de-rating must consider harmonic content of current waveform).
 - ⑩ C37.04.a-2003 Class C2 at 15 kV.
- 38 kV, 2500A and 3000A WC breakers are not rated for rapid reclosing.

Extra Capability Type VCP-WC Ratings (Symmetrical Current Basis), continued

Rated Values	Circuit Breaker Type					
	270 VCP-W 32C	270 VCP-W 40C	380 VCP-W 16C	380 VCP-W 25C	380 VCP-W 32C	380 VCP-W 40C
Voltage						
Maximum voltage V kV rms	27	27	38	38	38	38
Voltage range factor K	1	1	1	1	1	1
Insulation level—withstanding test						
Power frequency (1 min.) kA rms total	60	60	80	80	80	80
Lighting impulse 1.2 x 50 μ s kV peak	125	125	170	170	170	170
Continuous current at 60 Hz A rms						
	1200	1200	600	600	600	1200
	1600	1600	1200	1200	1200	2000
	—	—	1600	1600	1600	2500
	—	—	2000	2000	2000	3000FC ^④
	—	—	—	—	2500	—
	—	—	—	—	3000FC ^⑤	—
Short-circuit current						
Sym. interrupting at voltage (I _{sc}) kA rms total	31.5	40	16	25	33.1	40
% DC component (I _{dc})	55	50	75	65	57	63
Asym. interrupting (I _h) kA rms	40	49	23.3	34.0	42.5	53.5
Closing and latching capability kA peak	100	112	50	75	91	107
Short-time current for 3 seconds kA rms ^①	31.5 ^⑥	40 ^⑦	16	25	31.5 ^⑥	40
Interrupting time rms ^②	50	50	50	50	50	50
Maximum permissible tripping delay sec.	2.0	2.0	2.0	2.0	2.0	2.0
Rate of rise of recovery voltage (RRRV) kV/μs ^③						
	1.1	1.1	0.7	0.7	0.7	0.7
	—	—	0.7	0.7	0.7	—
	—	—	1.3	1.3	0.7	—
	—	—	—	—	1.3	—
	—	—	—	—	0.7	—
	—	—	—	—	1.3	—

Notes

^① Except as noted.

^② Three cycles.

^③ Contact Eaton for higher RRRV or for more information.

^④ 2500A FC to 3000A.

^⑤ 2000A FC to 3000A.

^⑥ 1.6 seconds.

^⑦ 1 second.

^⑧ 2.5 seconds.

38 kV, 2500A and 3000A WC breakers are not rated for rapid reclosing.

Extra Capability Type VCP-WC Ratings (Symmetrical Current Basis), continued

	Circuit Breaker Type					
	270 VCP-W 32C	270 VCP-W 40C	380 VCP-W 16C	380 VCP-W 25C	380 VCP-W 32C	380 VCP-W 40C
Rated Values, continued						
Capacitor switching ratings						
General purpose—isolated shunt capacitor bank current A rms	400	400	250	250	250	—
	—	—	250	250	250	—
	—	—	250	250	250	—
	—	—	250 and 1000	250 and 1000	250 and 1000	—
	—	—	—	—	—	—
	—	—	—	—	250 and 1000	—
Definite purpose—back-to-back capacitor switching						
Capacitor bank current A rms	400	400	250	250	250	—
	—	—	250	250	250	—
	—	—	250	250	250	—
	—	—	250 and 1000	250 and 1000	250 and 1000	—
	—	—	—	—	—	—
	—	—	—	—	250 and 1000	—
Inrush current kA peak						
	20	20	20	20	20	—
	—	—	20	20	20	—
	—	—	20 and 20	20 and 20	20 and 20	—
	—	—	—	—	—	—
	—	—	—	—	20 and 20	—
Inrush frequency kHz						
	4.2	4.2	4.4	4.4	4.4	—
	—	—	4.4	4.4	4.4	—
	—	—	4.4	4.4	4.4	—
	—	—	5 and 5	5 and 5	5 and 5	—
	—	—	—	—	—	—
	—	—	—	—	5 and 5	—
Mechanical Endurance—No-Load Operations	5000	5000	10,000	10,000	10,000	10,000

Note

38 kV, 2500A and 3000A WC breakers are not rated for rapid reclosing.

C-HRG Free-Standing NEMA 1 Unit



7

Product Description

Where continuity of service is a high priority, high resistance grounding can add the safety of a grounded system while minimizing the risk of service interruptions due to grounds. The concept is a simple one: provide a path for ground current via a grounding transformer (with adjustable resistance across its secondary) that limits the current magnitude and a monitor to determine when an abnormal condition exists.

The ground current path is provided at the point where the service begins, by placing a predominantly resistive impedance in the connection from system neutral to ground. Control equipment continuously measures ground current; a relay detects when the current exceeds a predetermined level. An alarm alerts building personnel that a ground exists. The system has built-in fault tracing means to assist in finding the source of the ground. A 120 Vac supply (remote) is required for control power for the system.

Application Description

This member of Eaton's MV metal-clad switchgear family has actually been around for many years. The free-standing C-HRG provides a standalone unit that can be added to existing installations. The C-HRG is used to protect an electrical distribution system from damaging transient overvoltages caused by ground faults. It also provides a means to locate the ground fault, therefore extending the life of the distribution system.

Ratings and Configurations

The C-HRG MV is offered at the 5 kV class rating. It can be applied to delta or wye ungrouped three-wire distribution systems.

Contents

<i>Description</i>	<i>Page</i>
High Resistance Grounding System	
Features, Benefits and Functions	V3-T7-21
Standards and Certifications	V3-T7-21
Catalog Number Selection	V3-T7-22
Technical Data and Specifications	V3-T7-23
Dimensions	V3-T7-26

4200V (Maximum) Delta Systems

To add high resistance grounding to an ungrounded delta-connected system, a neutral point must be created. Three single-phase transformers can be interconnected in a wye-broken delta configuration to provide such a neutral point. The transformers and grounding resistors are chosen to limit the ground current to a maximum value of 6A.

Note: The neutral point may not be used to serve phase-to-neutral loads. Also, this technique may be applied on wye-connected sources when the neutral point is not conveniently accessible from the service entrance location. This method is shown in the illustration shown on **Page V3-T7-24**. One delta high resistance grounding would ground the 5 kV system.

4200V (Maximum) Wye Systems

To add high resistance grounding to a wye-connected system, resistors are placed across the secondary of a grounding transformer whose primary is placed in series with the neutral-to-ground connection of the power source. The resistors are chosen to limit the current to a maximum value of 6A.

Note: Per 1993 NEC® 250.5b, exception No. 5, line-to-neutral loads may not be connected to a system in which the neutral is resistance grounded. Also, if the system has two switchable sources not permanently connected to the bus, two wye-type grounding systems are required as shown on **Page V3-T7-24**.

Ground Current Detection

Any time a system is energized, a small ground current called the “capacitive charging current” will be observed. For medium voltage (4200V and below) systems, this naturally occurring current is typically 3A or less.

When one phase becomes grounded, additional current above the charging level will flow. As all ground current must flow through the grounding resistor/grounding transformer assembly, an ammeter in this circuit will read the total amount of ground current. By placing a current-sensing relay in series with the ammeter, the current relay can be adjusted to pick up at a level in excess of the capacitive charging current, thus indicating the abnormal condition.

Alternatively, an optional voltmeter-relay can be connected across the grounding resistors. The voltage across the resistors is proportional to the amount of ground current. The voltmeter-relay’s pickup adjustment is set above the capacitive charging current, to the desired detection level.

In both current and voltage detection methods, the ground current ammeter provides a direct reading of the total actual ground current present in the system at that time. It will be helpful to periodically note the ammeter’s reading: a trend toward higher values may indicate the need for equipment maintenance, and hence reduce the occurrence of unplanned shutdowns.

Indication and Alarm Circuits

When a fault is detected, an adjustable time delay is provided to override transients. When the time delay has been exceeded, the green “normal” light will turn off, the red “ground fault” light will turn on, and the ground alarm contacts will transfer. If equipped with the optional alarm horn, it will sound.

The grounding transformer secondary breaker must be closed for the system to be operational. Should this breaker be opened at any time, the system will signal a ground fault condition as a fail-safe feature. The breaker must be closed to clear the alarm signal.

When the fault is cleared, the current/voltage relay will reset. If the reset control is set on “auto,” the lights will return to “normal” on, “ground fault” off, and the ground alarm contacts will re-transfer. If the reset control is set on “manual,” the lights and relay contacts will remain latched until the operator turns the reset control to “reset.” The lights and ground alarm contacts will then return to normal. The system can be reset only if the fault has been cleared.

During a fault, the optional alarm horn can be silenced at any time by using the “alarm silence” pushbutton. It will not re-sound until either the system is reset, or the re-alarm timer expires. The re-alarm timer is activated by the “alarm silence” control. If the horn has been silenced but the fault has not been cleared, the timer will run. It has a range of 2–48 hours. When the timer times out, the horn will re-sound, alerting maintenance personnel that the fault has not been cleared.

Test Circuit

A test circuit is provided to allow the user to quickly determine that the system is working properly. The test circuit will operate only under normal conditions—it will not allow testing if the system is sensing a fault. The test operation does not simulate an actual system ground fault. It does, however, test the complete controls of the fault indication and pulsing circuitry. The system then reacts as it would under actual system ground conditions—lights transfer, alarm contacts transfer and the (optional) horn sounds.

Pulser Circuit

The pulser circuit offers a convenient means to locate the faulted feeder and trace the fault to its origin. The pulser is available any time a fault has been detected. The pulse intervals are controlled by an adjustable recycle timer. The “pulse” light flashes on and off, corresponding to the on-off cycles of the pulser contactor. The pulser contactor switches a bank of resistors on and off, thus allowing a momentary increase in the ground current (approximately a 4A current pulse above the ground current).

Locating a Ground Fault

The current pulses can be noted with a clamp-on ammeter when the ammeter is placed around the cables or conduit feeding the fault. The operator tests each conduit or set of cables until the pulsing current is noted. By moving the ammeter along the conduit, or checking the conduit periodically along its length, the fault can be traced to its origin. The fault may be located at the point where the pulsing current drops off or stops.

If little or no change in the pulsing current is noted along the entire length of a conduit, then the fault may be in the connected load. If the load is a panelboard, distribution switchboard or motor control center, repeat the process of checking all outgoing cable groups and conduits to find the faulted feeder. If the fault is not found in an outgoing feeder, the fault may be internal to that equipment.

Note: It may not be possible to precisely locate faults within a conduit. The ground current may divide into many components, depending on the number of cables per phase, number of conduits per feeder, and the number and resistance of each ground point along the conduits. The resulting currents may be too small to allow detection or may take a path that the ammeter cannot trace. An important note to keep in mind is that while the pulser can greatly aid in locating a fault, there may be certain conditions under which the pulses cannot be readily traced, and other test procedures (megohm, high-potential, etc.) may be needed.

Sequence of Operations**Normal**

- Green “normal” light on
- Red “ground fault” light off
- White “pulse” light off
- System control switch in “normal” position
- Reset control switch in either “auto” or “manual”

Test

Turn and hold the system control switch in the “test” position. This mode will test the control circuitry only. It will bypass the sensing circuit and cause the green “normal” light to turn off and the red “ground fault” light to turn on. The pulser will be activated as well. The white “pulse” light will turn on and off as the pulser contactor closes and opens. However, the ground current ammeter will not display the total ground current, including the incremental pulse current. When ready, return the system control switch to “normal.” The pulser will stop. If the reset control is in the “manual” position, turn it to “reset” to reset the fault sensing circuit. The red “ground fault” light will turn off, and the green “normal” light will turn on. Test mode is not available if the system is detecting a ground. The sensing circuit will disable the test circuit.

Ground Fault

When the sensing circuit detects a fault, the green “normal” light will turn off and the red “ground fault” light will turn on. The ground current ammeter will indicate the total ground current. To use the pulser, turn the system control switch to “pulse.” The pulser contactor will cycle on and off as controlled by the recycle timer relay. Use the clamp-on ammeter to locate the faulted feeder. Open the feeder and clear the fault. If the reset control switch is in the “manual” position, turn it to “reset” to reset the sensing circuit. (If reset control is in “auto,” it will reset itself.) When ready to restore service to the load, close the feeder. Return the system control to “normal.”

Features, Benefits and Functions

When a ground fault occurs on an ungrounded system, high transient voltages can occur, which may cause more frequent equipment failures than if the equipment were grounded. These transient overvoltages, as high as four times the normal voltage, reduce the life of the system's insulation resulting in:

- Motor failure
- Transformer failure
- Coil failure
- Electronic equipment failure
- Cable insulation failure

By using a high resistance ground system, many facilities can gain the benefit of a grounded system without impairing the continuity of service to their equipment. The concept behind high resistance grounding is to provide a path for the ground current to flow while limiting its magnitude by using a resistor. The ground current path is provided at the point where service begins. Control equipment continuously monitors the magnitude of the ground current.

When the ground current exceeds a predetermined level, the built-in alarm relay alerts building personnel that a ground fault exists. In addition, the C-HRG MV "safe ground" system has a built-in fault pulsing as a means to assist in finding the source of the ground fault without interrupting service.

- Current sensing ground fault detection (2–10A pickup/ 0.5–20 second delay)
- Ground current transformer (10/10 ratio)
- Control circuit pull fuseblock
- Ground current ammeter (0–10A, 1% accuracy)
- Indicating lights:
 - Red (ground fault)
 - Green (normal)
 - White (pulse)
- Adjustable pulsing timer (0–10 seconds)
- Tapped resistors (limits primary current to 3–6A)
- Three-position selector switch (normal, pulse, test)
- Control switch for manual or automatic reset
- Ground fault contacts (1NO/1NC)
- Shorting terminal block for ground current CT
- UL label
- Wiremarkers

Standards and Certifications

The system shall be completely assembled, wired and tested at the factory in accordance with NEMA and UL requirements. A certified production test report shall be shipped with the unit.



7.3

Medium Voltage Switchgear

High Resistance Grounding System

Catalog Number Selection

A C-HRG High Resistance Grounding Assembly can be completely described by an 8-digit catalog number: MVRG-_____

High Resistance Grounding Systems

MVRG F X D D N L T S

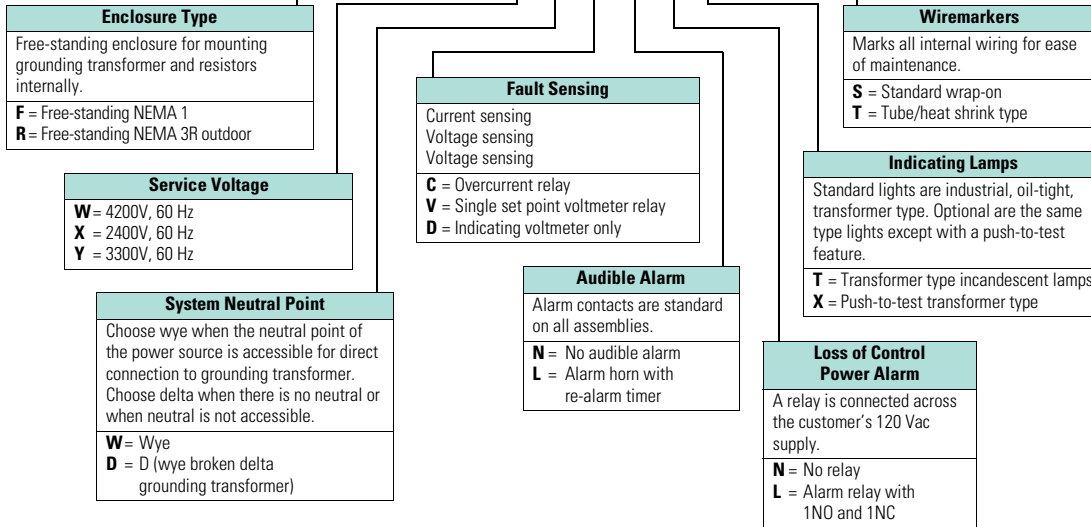

Example: MVRG-FWWCLLTS defines a free-standing NEMA 1 enclosure, 4200V/60 Hz, wye-connected system, current-sensing control scheme, alarm horn with re-alarm timer, alarm relay with 1NO and 1NC, transformer type incandescent lights, wrap-on wiremarkers.

Technical Data and Specifications

General

Provide a high resistance grounding system as a means to provide a path for ground current via a resistance that limits the current magnitude. While monitoring the ground current, the system must be able to determine when an abnormal condition exists. Once the abnormality is detected, the system shall alert building personnel that a ground exists. The system shall be suitable for 5000V maximum service, and designed and tested for that voltage class in accordance with the latest standards of NEMA and UL.

- Tapped resistors supply primary ground current between 3 and 6A in 1A increments
- Pulse current is an additional 4A. (pulse currents of a lower magnitude may be difficult to detect)
- Pulse timer is adjustable from 3 to 60 pulses per minute
- Time delay for current sensing relay is 0.5 to 20 seconds with a 2 to 10A pickup. Time delay for voltage sensing relay is 1 to 60 seconds
- "Pull-type" fuse disconnects are supplied for control equipment protection
- All exterior nameplates are fastened with stainless steel screws
- Nameplates are 2-ply with 3/16-inch (4.8 mm) lettering. The nameplate size is 1-inch (25.4 mm) x 2-1/2-inch (63.5 mm). White background with black lettering is standard
- Top and bottom cable entry areas
- Phase and neutral terminals accept #4 AWG to 500 kcmil
- Ground terminal accepts wire sizes from #4 AWG to 500 kcmil. Ground bus is 1/4-inch (6.35 mm) x 2-inch (50.8 mm) copper
- The powder paint is applied to the parts electrostatically. Metal surfaces are prepared by spray cleaning and phosphatizing. The powder paint is a polyester urethane. The standard color is ANSI 61, light gray. The paint is applied to a thickness of 1.5 mil
- Appropriate current limit drawout type fuses are provided. The chassis is mechanically interlocked with a secondary circuit breaker to prevent its withdrawal under load conditions
- Resistors are grid type to provide the maximum area for heat dissipation
- No. 4 AWG wire is used for internal connections from the neutral point to ground. Control connections are a minimum of #14 gauge. All control wires insulation is type SIS
- Recommended spare parts list
- Steel pocket on the inside of the door is provided to hold drawings and manuals

Note: The C-HRG units can be applied on any three-wire distribution system, regardless of the manufacturer of the distribution equipment or source power transformer.

System Ratings and Features

Provide a UL-labeled high-resistance grounding system equal to Eaton catalog number _____ for use on a system with a short-circuit capacity of ___kA at ___ volts. The structure shall be a [free-standing NEMA 1] [free-standing NEMA 3R]. The system neutral point shall be provided by [the power transformer's wye neutral point] [wye-broken delta grounding transformers]. The ground current shall be detected with [an overcurrent relay] [a single set point voltmeter relay]. [An alarm horn with re-alarm timer is required.] [An alarm to indicate the loss of control power is required.] The indicating lights shall be [transformer-type incandescent lamps] [push-to-test transformer type lamps]. Control wiring shall be marked using [wrap-on type] [heat-shrink sleeve type] wiremarkers. [A portable clamp on detector with 1/2/5/10/20A scales, a shorting switch and a storage case is required].

In addition to the components specified, the following shall be supplied with each system:

- Ground current transformer (10/10 ratio)
- Control circuit disconnect switch (fused)
- Ground current ammeter (0–10A, 1% accuracy)
- Control switch for manual or automatic reset
- Ground fault contacts (1NO/1NC) for customer use
- Shorting terminal block for ground current CT
- Adjustable pulsing timer (0–10 seconds)
- Tapped resistors (across neutral forming transformer secondary, limiting primary current to 3–6A)
- Three-position selector switch (normal, pulse, test)
- Indicating lights:
Red (ground fault)
Green (normal)
White (pulse)

Components and Connections

Phase and neutral terminals shall accept #4 AWG to 500 kcmil wire. Ground terminals shall accept wire sizes from #8 AWG to 500 kcmil. Ground bus shall be 1/4-inch (6.35 mm) x 2-inch (50.8 mm) copper. #4 AWG wire shall be used for all internal connections from the neutral point to ground. Control connections shall be a minimum of #14 gauge. All control wire insulation shall be type SIS. All control wiring shall be labeled at each end. Wiring within the resistor assembly shall be rated for 200°C service.

Structure

The unit shall be free-standing and house the resistor bank within an isolated section of the structure. Access to the resistor shall be via a bolted-on cover. The rear cover shall be removable. The structure shall provide top and bottom cable entry points. Lifting angles shall be provided to facilitate the installation of the unit. The structure shall be suitable for moving on rollers and shall be skidded for shipment in a manner suitable for handling by a forklift.

All steel parts (except for plated parts) shall be thoroughly cleaned and phosphatized prior to the application of the light gray ANSI No. 61 finish. A pocket is required on the inside of the control compartment door to store drawings and manuals.

7.3

Medium Voltage Switchgear

High Resistance Grounding System

Wiring Diagram

HRG—High Resistance Grounding System

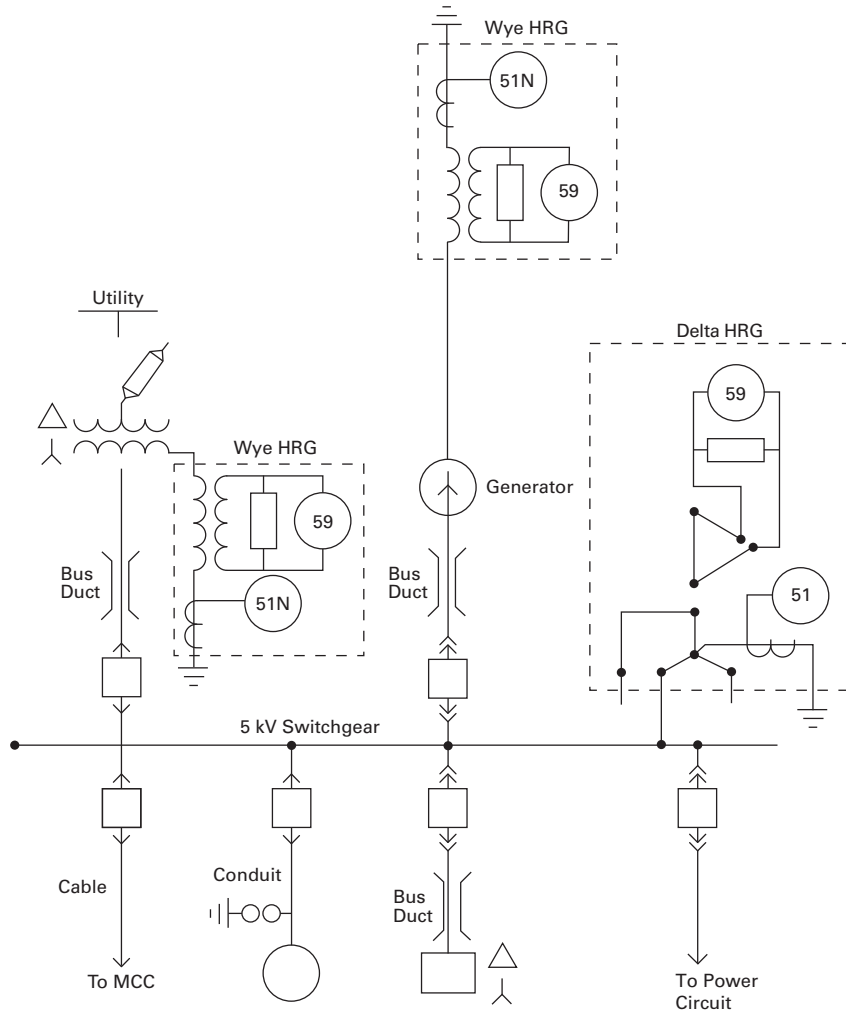

Circuit Diagrams

Ungrounded Wye System (with standard current and optional voltage relay fault detectors)

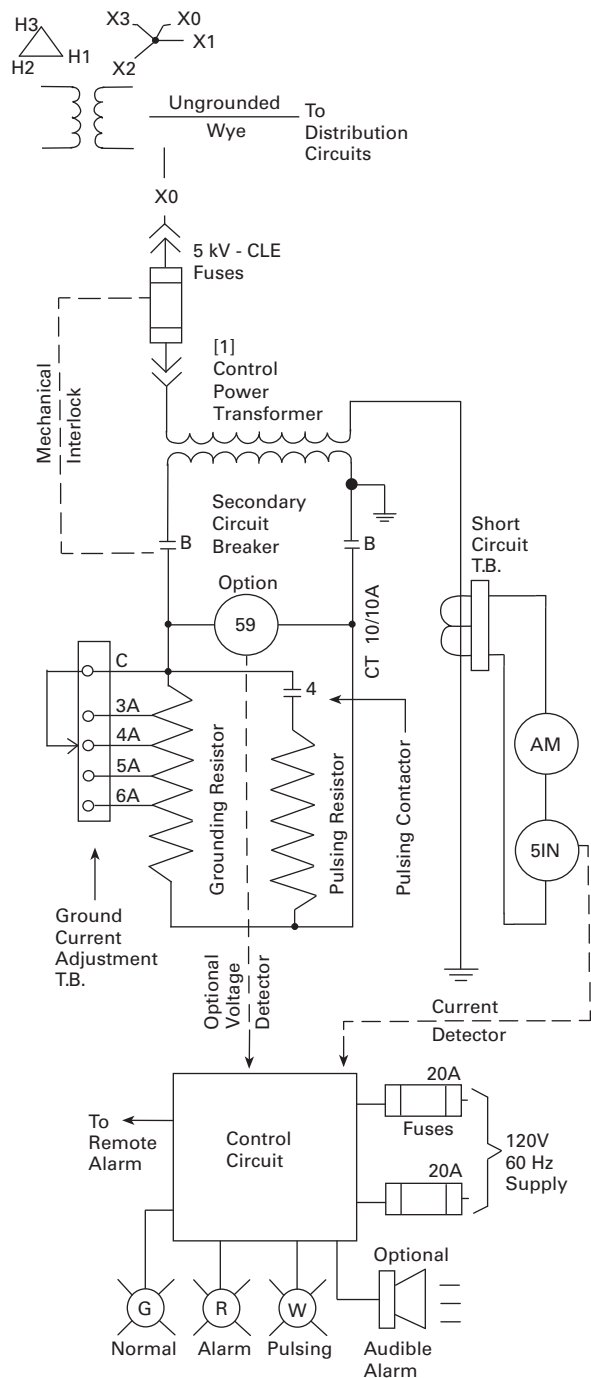

Ungrounded Delta System (with standard current and optional voltage relay fault detectors)

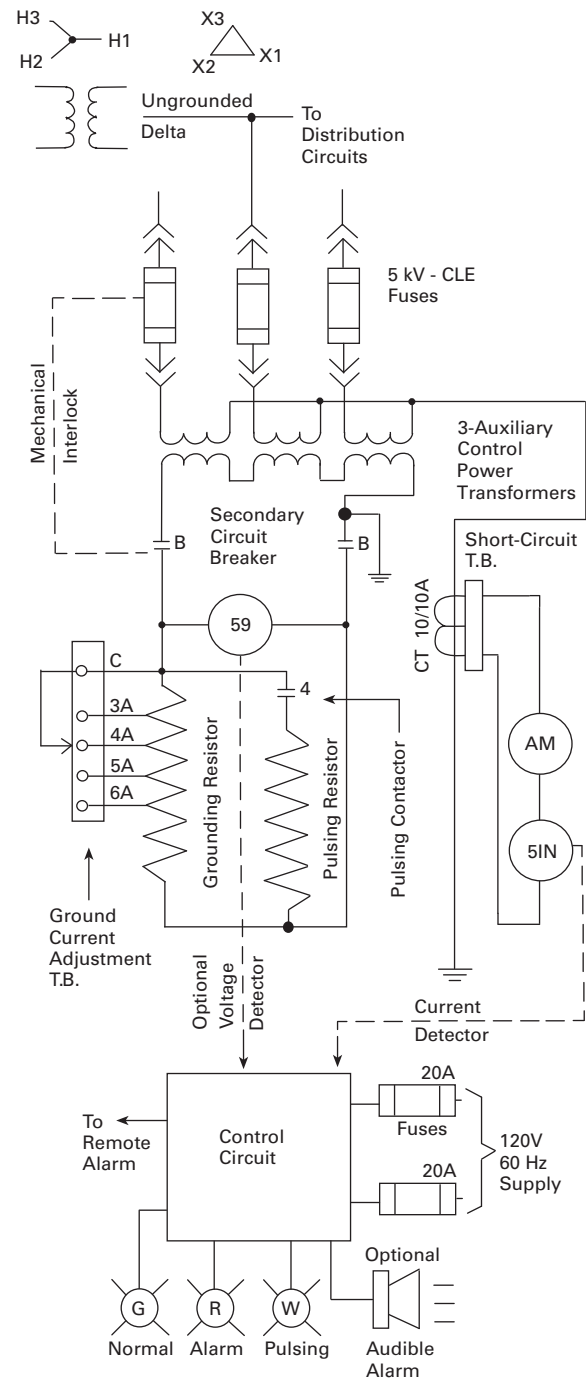

7.3

Medium Voltage Switchgear

High Resistance Grounding System

Dimensions

Approximate Dimensions in Inches (mm)

NEMA 1 Free-Standing

7

